

FA
50N

FACADE SYSTEM



complex solutions

FA 50N – SYSTEM FEATURES

- allows for creating constructions of various shapes and dimensions, in accordance with the architect's vision,
- complies with valid standards concerning water tightness, thermal insulation and fire resistance,
- wide variety of masking strips allows for diversified final appearance of curtain walls,
- possibility of bending profiles,
- possibility of creating many varieties with diversified parameters,,
- possibility of using photovoltaic cells,
- thanks to a wide range of solutions included in the system, it is possible to freely shape the façade in terms of geometric and colour. The product has also been tested in one of the European research institutes,
- FA 50N system is classified as one of best curtain wall system available on the market, considering thermal and acoustic insulation, water tightness and wind load resistance.



See the product
on the website

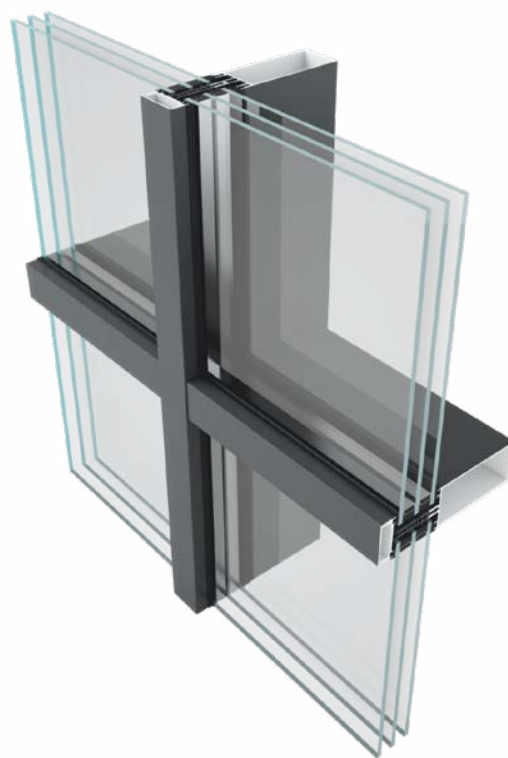

Pictures: CELEBRO, Warsaw
Design: Kuryłowicz & Associates Sp z o.o., Warsaw,
Aluminium manufacturer: Alures Sp. z o.o., Boguchwała



CROSS SECTION THROUGH
FA 50N MULLION WITH TM 77N WINDOW

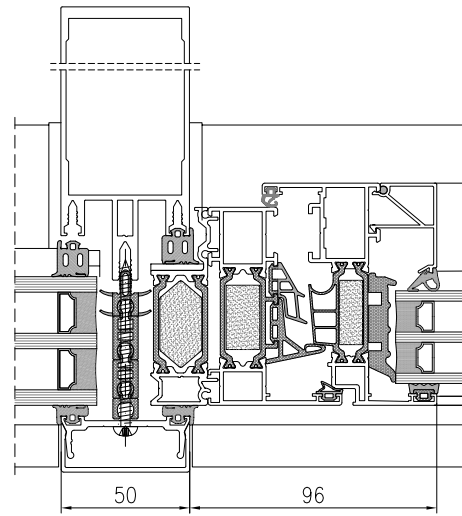

CROSS SECTION THROUGH
FA 50N TRANSOM

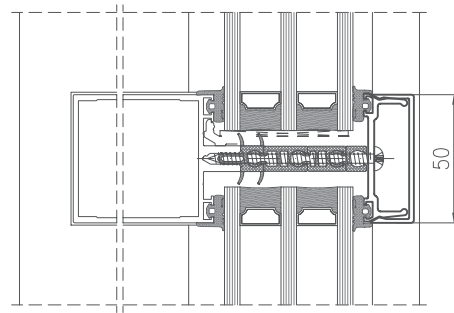

TECHNICAL PARAMETERS - FA 50N

ENERGY	Thermal insulation EN 10077-2	$U_f = 1,14 \div 1,88 \text{ W/m}^2\text{K}$
COMFORT	Acoustic insulation EN ISO 140-3	$R_w = 35 \div 53 \text{ dB}$
	Air permeability EN 12207	AE 1650
	Water tightness EN 12208	RE 2850
SAFETY	Wind load resistance EN 12210	2400 Pa
	Anti-theft protection EN 1627	RC2, RC3, RC4
	Impact resistance EN 14019	I5, E5

TECHNICAL PROPERTIES - FA 50N

Minimum visible width (view from inside)	50 mm
Minimum visible width (view with outside)	50 mm
Minimum mullion depth	34 mm
Maximum mullion depth	350 mm
Glazing thickness	$6 \div 64 \text{ mm}$
Glazing method	Glazing with pressure element